

# MINIBEAST MODELS

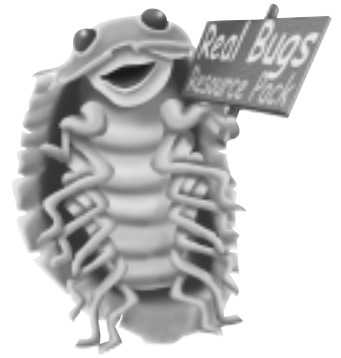

These models are very easy to make using:

1. Plastic coffee cups
2. Drinking straws with a bendy section
3. Sticky tape
4. Sheets of card

Choose what minibeast you want to make and collect a coffee cup body plan sheet.

## 1. STICK THE BODY TOGETHER

If the cups are facing the same way, you need to attach a card circle to them. Cut out the card circles and attach them onto the open end of the cups. Stick in place with sticky tape.

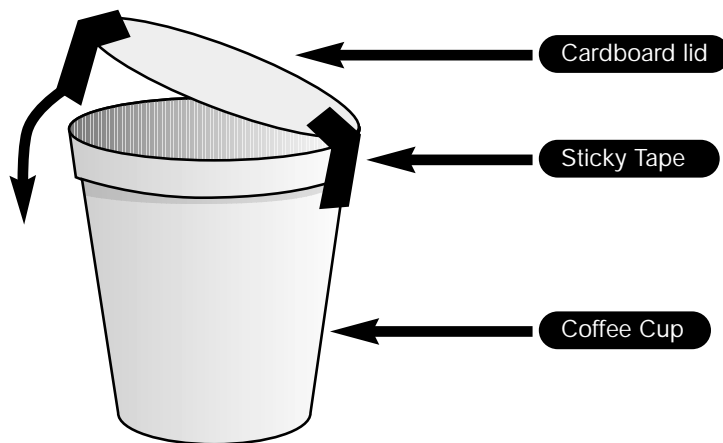

Now you're ready to stick the body together using the body plan.

## 2. ADD THE LEGS.

Cut the straws to make the legs. Make a hole in the cup with scissors (take care when doing this) and push the legs into the holes, or stick the legs to the outside of the body using sticky tape.

## 3. STICK ON THE FACE.

Cut out the face and any other parts supplied on the sheets and stick them on to the animal.

## 4. DECORATE YOUR COFFEE CUP BUG.

Use the coloured sticky tape to decorate your minibeast. You could even draw patterns onto paper and stick this on to your model. Don't forget that if the model is plastic you will not be able to use pens to colour it.



# MINIBEAST MODELS



## Body plans for cup centipedes or millipedes

You will need: 5 coffee cups and 5 or 10 straws.  
Cut around the pictures to complete your bug.

### CENTIPEDE

Centipedes have one pair of legs on each body segment (they have up to 80 segments, but you should make a shorter centipede with 5 segments)

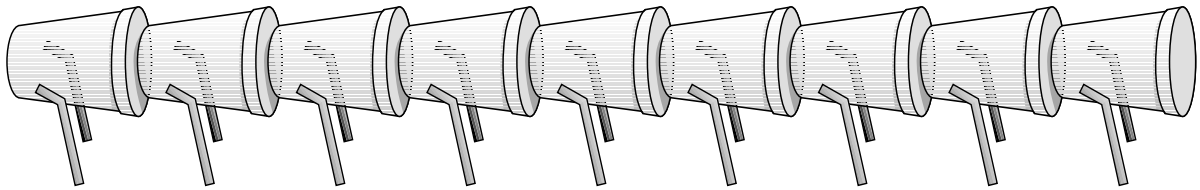

### MILLIPEDE

Millipedes have two pairs of legs on each body segment

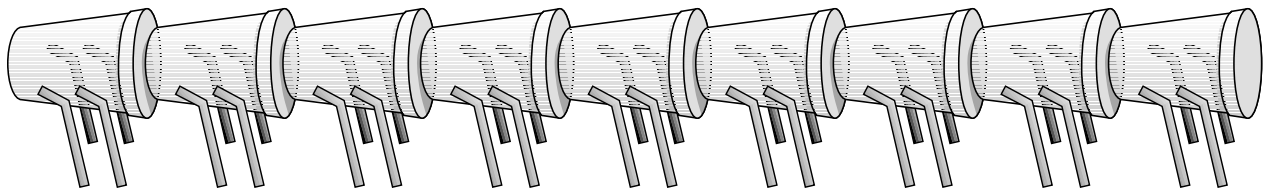

Millipede (face)

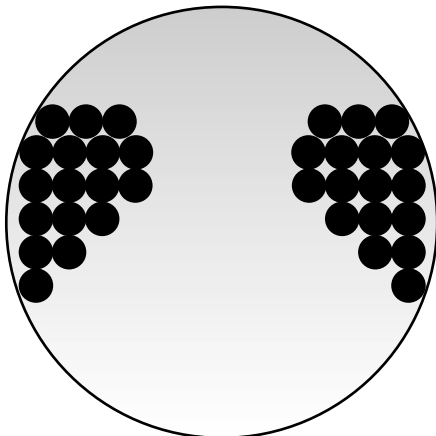

Centipede (face)

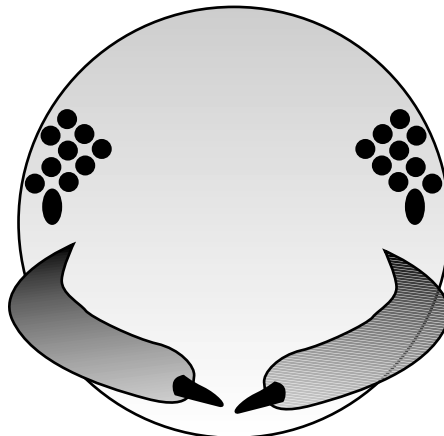

# MINIBEAST MODELS

## Body plans for cup spiders and harvestman

You will need: 2 or 3 coffee cups and 4 or 5 straws.  
Cut around the pictures to complete your bug.

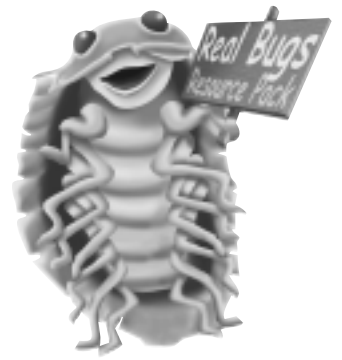

### SPIDER

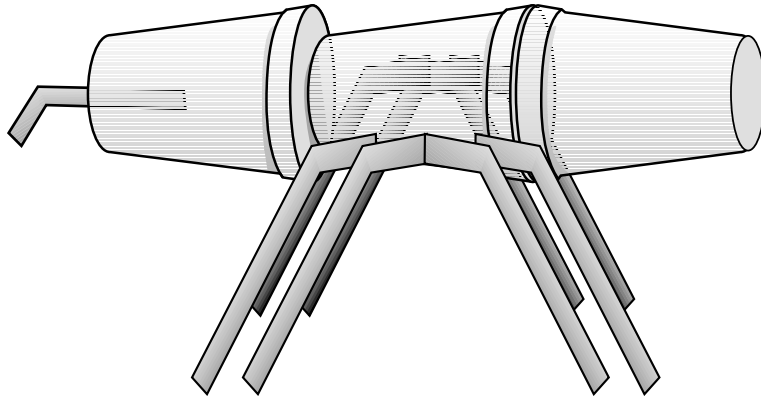

### HARVESTMAN

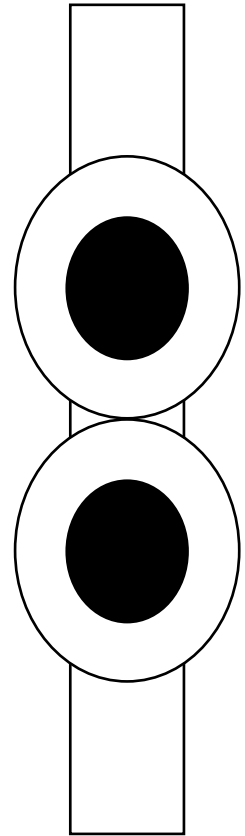
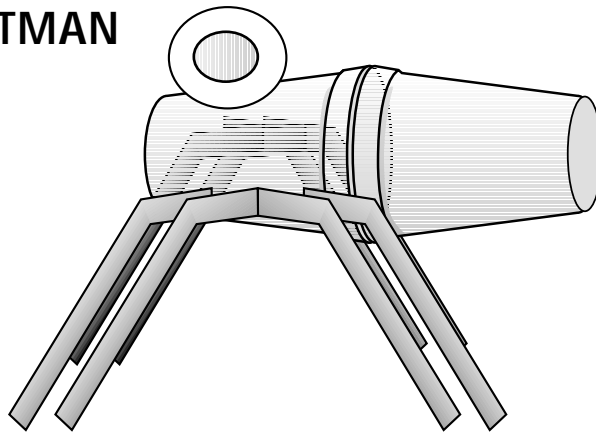

Harvestman (eyes)

Spider (face)

Harvestman (face)

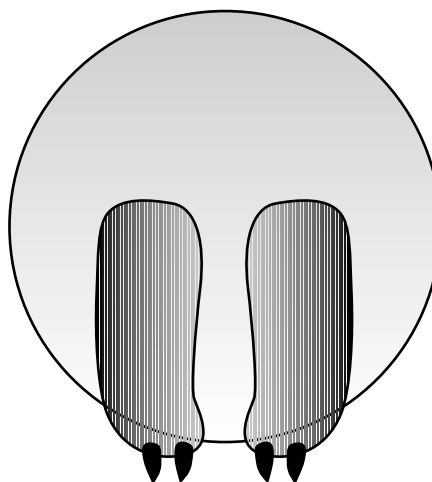
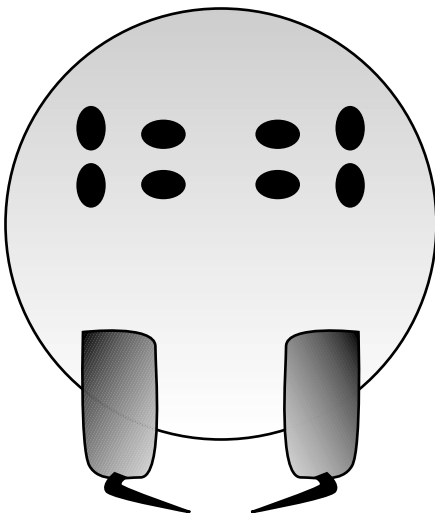

# MINIBEAST MODELS



## Body plans for a cup fly

You will need: 3 coffee cups and 6 straws.  
Cut around the pictures to complete your bug.

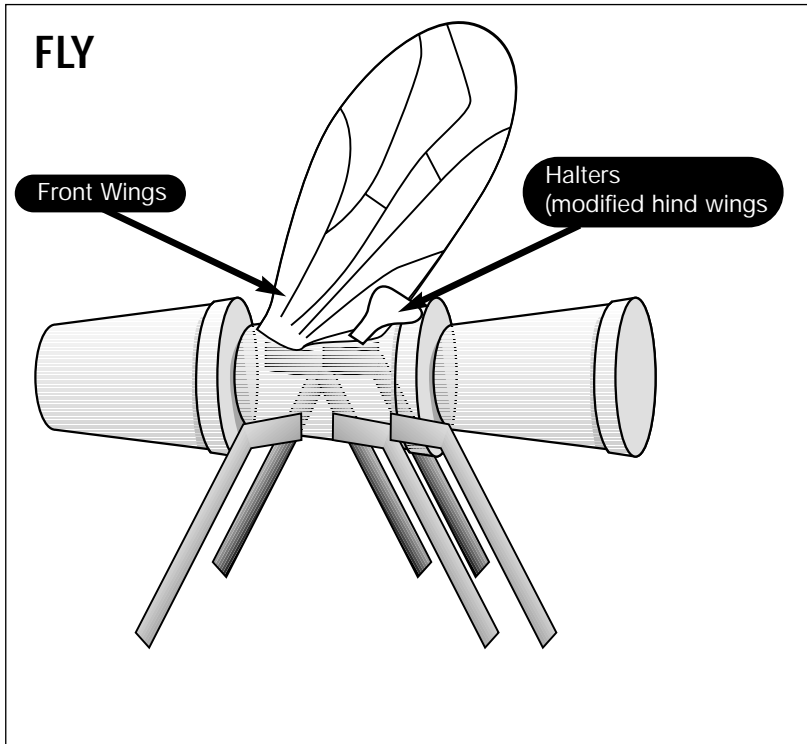

Wings

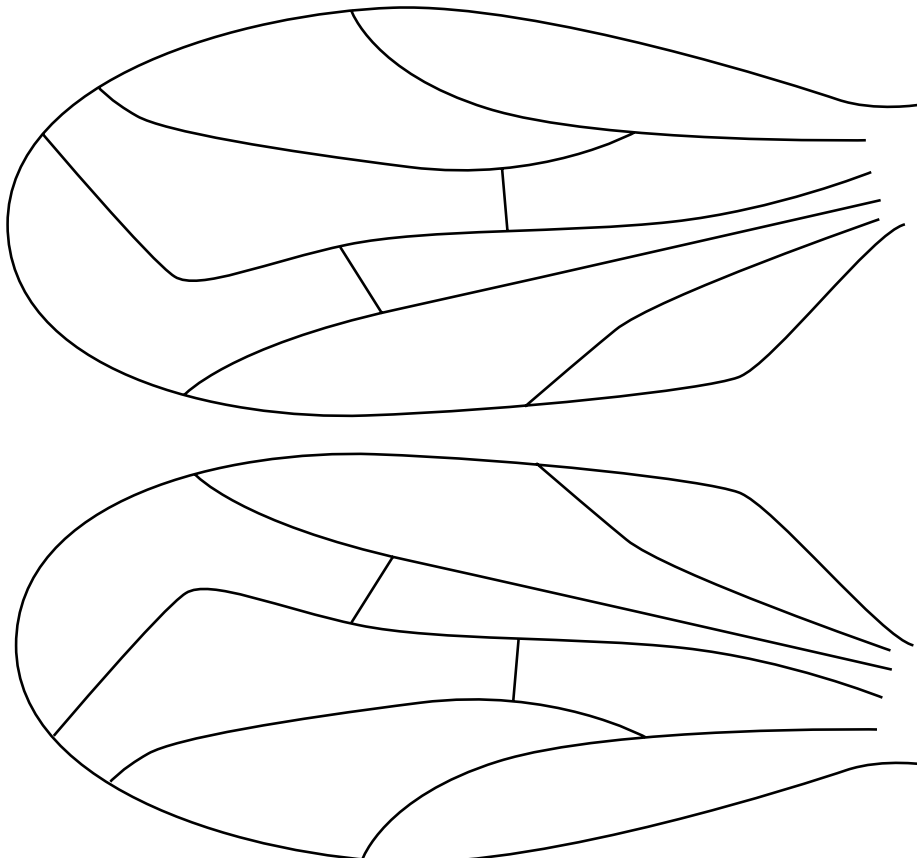

Fly (face)

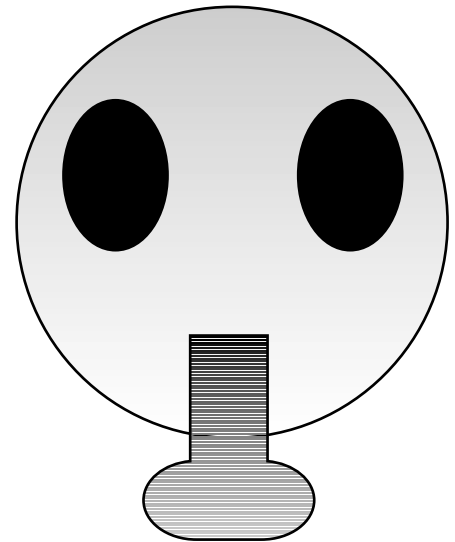

Fly Halters

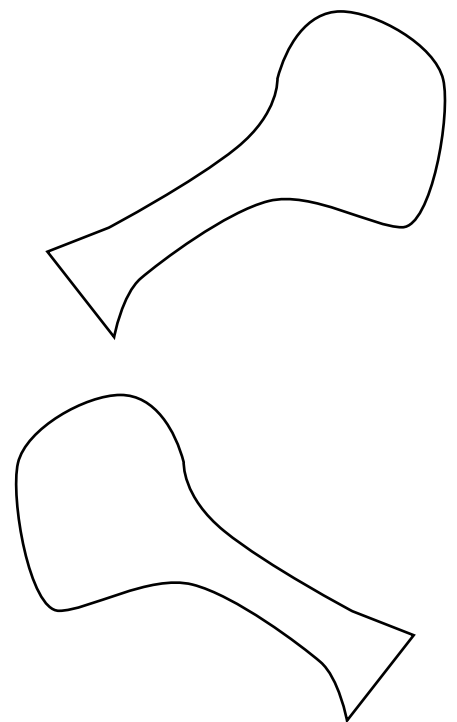

# MINIBEAST MODELS

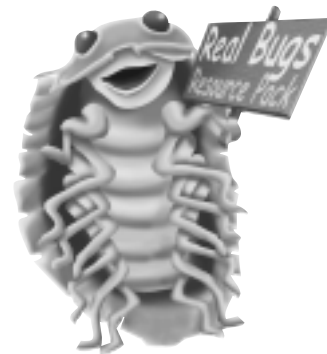

## Body plans for cup Bee or Wasp

You will need: 3 coffee cups and 6 straws.  
Cut around the pictures to complete your bug.

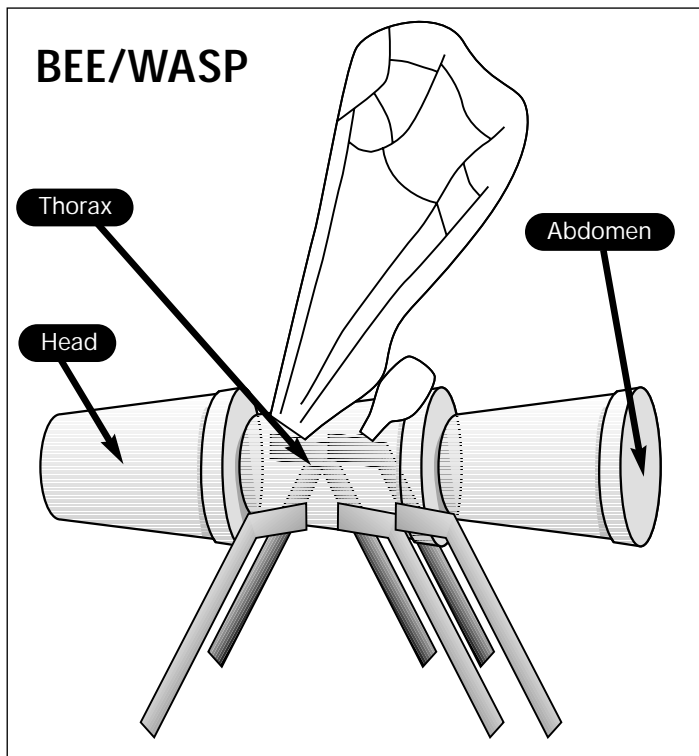

Bee/Wasp (face)

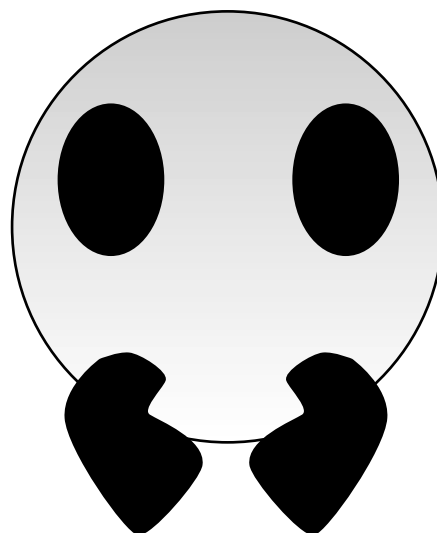

Back Wings

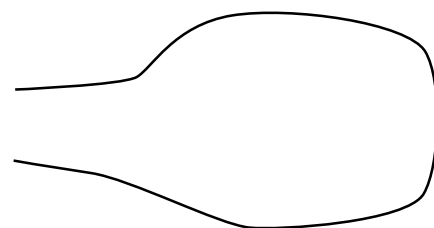

Front Wings

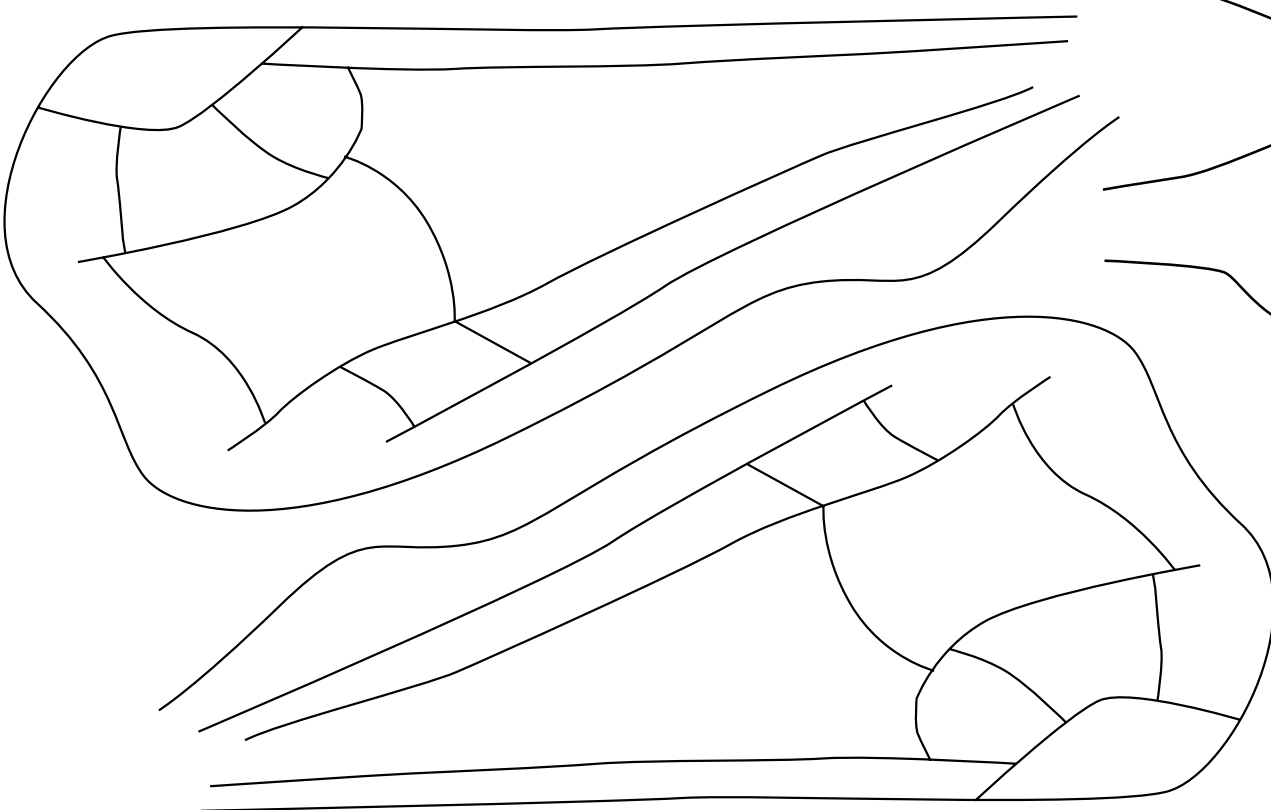

# OHP SHADOW PUPPETS

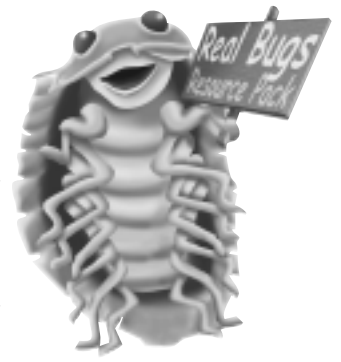

*Your class could devise and make their own Bug Show by making simple shadow puppets. An exciting way to stage it is with the use of an overhead projector (OHP). Jacolly Puppet Theatre are a successful touring puppet company, and they have kindly shared some of their techniques that are easy to use in the classroom.*

## You Will Need:-

- A darkened room
- An overhead projector (with protective sheet of clear acetate covering the glass)
- A projector screen (a blank wall or, if you want to use a human actor as well, a cotton sheet about 2m sq. See Fig 1)
- Pencils & rubbers
- Rough paper
- OHP pens (various colours)
- Sellotape
- Scissors

## For Puppets

- Paper Fasteners (i.e. the kind that look like tiny, metal clothes pegs!)
- Thin wire for control rods

## Silhouette Puppets

- Card (postcard thickness)
- Scraps of acetate

## Coloured Shadow Puppets

- Clear acetate sheets (postcard thickness)
- Diamond Ultraclear Sellotape (which does not show on acetate)

## For Scenery

- Card or stiff paper

## Coloured Scenery

- Sheets of clear acetate

First make a template of the OHP glass to help you to decide the size of your puppets. Remember that the further away your projector is from the screen the larger your images will appear e.g. a 20 cm high puppet projected from 2 m away appears the size of a real-life adult! This is one trick that puppeteers can use to include people in their puppet plays. If you hang a cotton sheet about 2 m square and project the puppet from behind the sheet rather than in front of the sheet, then the students can act behind the screen with the shadow from the puppet. This is the one time that your class can talk to a human-sized ant!

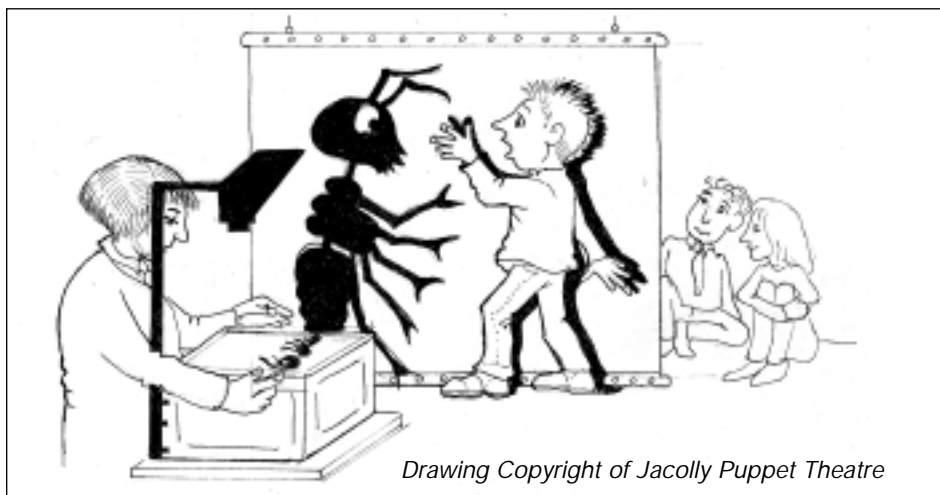

*Drawing Copyright of Jacolly Puppet Theatre*

*A simple screen is made by hanging a thin white sheet. It is a good idea to weight the sheet (using wooden bars) and to hang the screen so that the bottom is just off the floor.*

Most shadow puppets can be easily made from just card and acetate. We will show you some easy techniques to make silhouette and acetate puppets, and how to joint them to really bring your minibeasts to life.

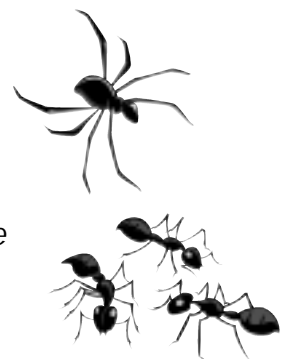

# MAKING THE PUPPETS



## SILHOUETTE PUPPETS

First ask the class to decide what puppet they want to make. They may need to draw a picture of the puppet first to visualise it. Remind them that for any features to be seen they can't be drawn onto the puppet, they will have to be cut out or cut around. You can add some colour to your silhouette puppets by sticking an acetate picture behind the card silhouette.



*Card silhouettes usually look best as a side view*



*The features do not show clearly from the front*



*...unless you cut them out*



*Silhouette puppets over acetate & paper scenery*



*Birds' eye view of silhouette puppets over acetate scenery*

## MAKING A COLOURED EYE FOR SILHOUETTE PUPPET

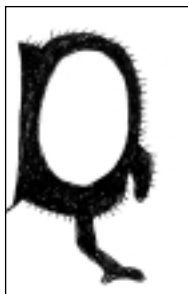

*Cut eye hole out of fly's head*

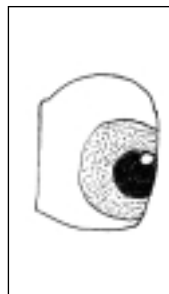

*Draw eye on acetate & colour with OHP pens*

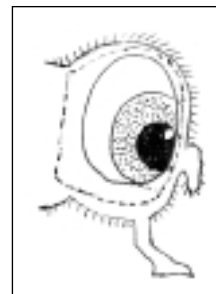

*Cut out & tape over eye hole*



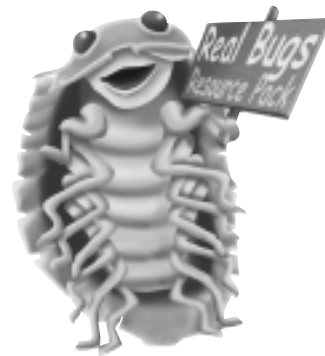

## MAKING A SIMPLE ACETATE PUPPET

Acetate puppets are easy to make as they are very similar to the pictures that the students have already drawn. Ask the class to draw the outline of their insect onto an acetate sheet. This can be coloured in with OHP pens and cut out. It is helpful if the central part is covered with card so that a control rod can be taped onto the body. Think about which way you will need to tape the control rod! Will your insect be flying from the top of the projector, or moving around in the grass at the bottom of the projector?

*Add the pictures and text from the sheet.*

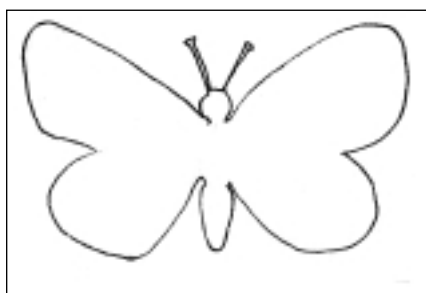

*Use an OHP pen to draw or trace the outline of butterfly onto an acetate sheet*

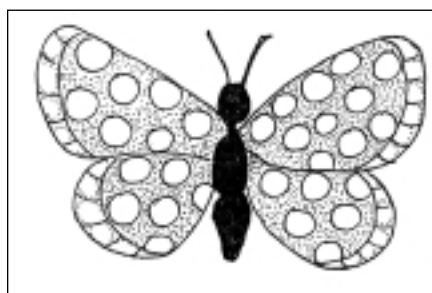

*Colour the wings with OHP pens, cover body with card and cut out*

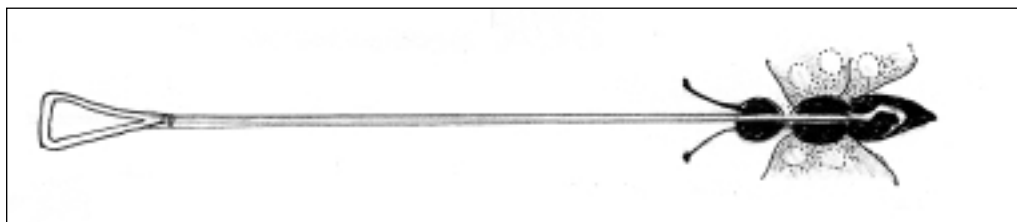

*Make the control rod out of thin wire and tape it onto the body*

## JOINTING YOUR PUPPET

Decide what actions your puppet needs to perform in your play. You can give your puppet movement by jointing it: But remember that it is hard to work more than two control rods at a time.

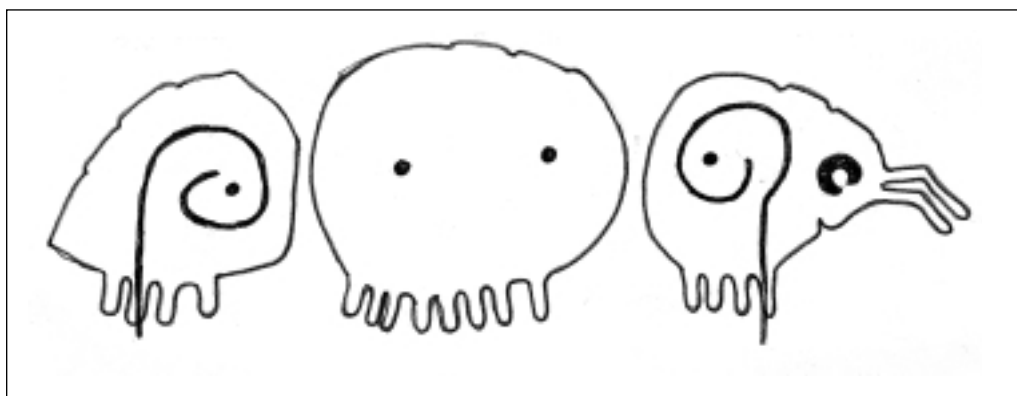

*Cut out sections & make holes for fasteners. Fix wire control rods on to head and abdomen with strong tape. Join section together, as shown above, with paper fasteners*





## MAKING THE PUPPETS

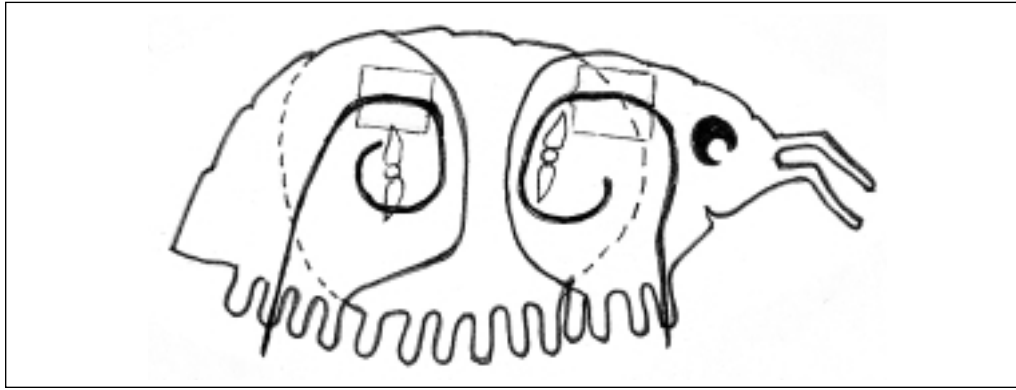

*It would be complicated to make all 14 sections of a woodlouse's legs move separately, but just moving the three jointed sections of this puppet woodlouse can give the impression that they do!*

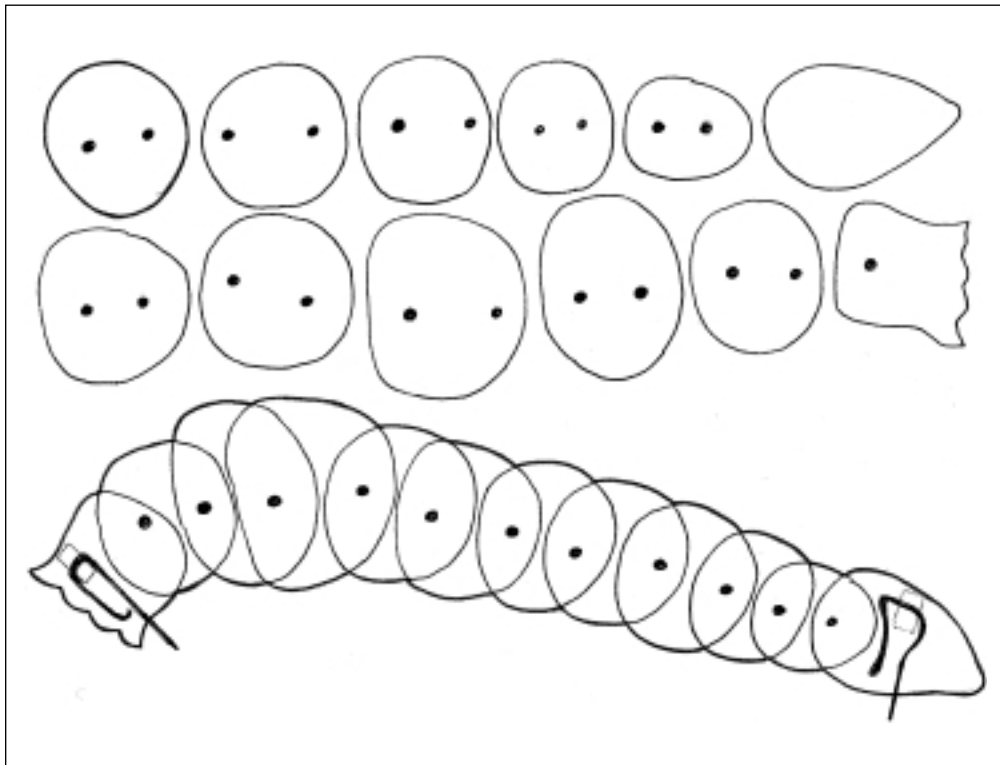

*If you want to make a very supple minibeast, it needs lots of joining. This maggot can easily be adapted to make, say, a caterpillar or millipede.*

*NB Although it is made in twelve segments, this maggot still only needs two control rods!*



# MAKING THE PUPPETS

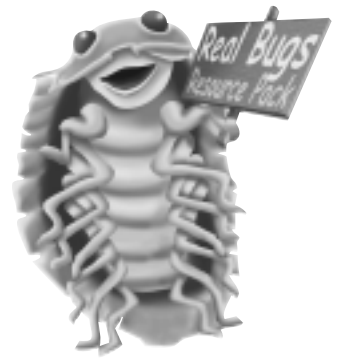

## SCENERY

The students may prefer to draw some scenery. This can be made by using an acetate sheet slightly larger than OHP glass, draw and colour the scenery with OHP pens. To add further drama to your scenery, frame your acetate sheet with silhouette shapes. Use a piece of card as big as the projector, and cut tree or grass shapes around the outside of the card to give the puppets a "stage" to perform in. Paper leaves can be cut and taped to surround the coloured acetate scenery.

## SUGGESTED ADDITIONAL MATERIALS

You can also experiment making your puppets and scenery with feathers, fur, net, lace, coloured cellophane, ferns & grasses.

### Points to Remember

- the OHP mirror will reverse the image you lay on the glass (i.e. your puppet will face in the opposite direction. Experiment and see!)
- Before fastening your paper puppet together, decide which way it is to face. Insert fasteners with the sharp ends away from the glass.
- As in a film, you can have close-ups (e.g. make a bug's head nearly fill the whole screen) or long shots (e.g. a swarm of bugs in the distance)
- To make your bug's wings look translucent, make out of acetate & decorate with OHP pens.
- Make the puppets' control rods long enough so that the puppeteer's hands are not seen over the glass when they are moving the puppet.
- Check your OHP before you use it, does it get hot? You should use heat resistant materials if it is warm.



# PERFORMING YOUR OWN PLAY



*Peter Smithers and Jacolly Puppet Theatre have created a set of scripts especially for classroom use. The scripts can either be used for the class to perform their own shadow puppet show (don't forget you'll need someone to work the puppet and someone to be the voice of the insect) or the class could act out the characters in a short play.*

## **On and the Roller Ball Crew**

is a full eight-page script, that can be downloaded as PDFs from the BBSRC website [www.bbsrc.ac.uk/schools](http://www.bbsrc.ac.uk/schools). This script has also been adapted into three smaller scripts.

## **Lunch-time with On and the Roller Ball Crew**

is a three-page script that deals with how different insects eat, with six characters.

## **Legless**

is a two-page script that deals with classification and grouping, but looking at the number of legs, with five characters.

## **On the ball**

looks at different types of woodlice, through a lively two-page script based around football. This script will be useful to introduce classification in science. You could also include this in assemblies that have a citizenship angle as there may be close parallels with people or things being the same even though they act differently or look different.



Jacolly Puppet Theatre present "Real Bugs"

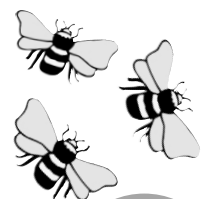

# Lunch-time with On and the Roller Ball Crew. 1

Written by Peter Smithers & Jacolly Puppet Theatre



## CAST

### *Puppets/Puppeteers*

ONISCUS, a woodlouse  
ARMADELIDIUM, another kind of woodlouse  
MARGO, a maggot  
SPECK, a butterfly  
DYSDERA, a woodlouse-eating spider

### *Voices*

NARRATOR  
ONISCUS, a woodlouse  
ARMADELIDIUM, another kind of woodlouse  
MARGO, a maggot  
SPECK, a butterfly  
DYSDERA, a woodlouse-eating spider

### *Scenery*

(card/paper/coloured acetate with fabric leaves)

### *Sound effect producers*

NARRATOR: Oniscus the woodlouse is out hunting for some high quality rotting leaves before the day becomes too hot for him.

*[MUSICIANS: accompany song in blues style]*

ON: *(Ambles in, singing.)*

I woke up this morning, I was hungry as a hog. I went over to the compost heap I could almost eat a log. Wanted some rotten leaves, but the ones there were all new. Oh, Oh, Oh, I got those rotten leaf blues.

NAR: On has to find leaves that are just right as, if they are too fresh, they are tough as old boots. But if they are too old they have too much fungus growing on them and they taste terrible. So he has to find just the right patch where the leaves are perfect.

*[SOUND EFFECTS: walking on dead leaves].*

ON: *(On wanders along looking at leaves and turning them over.)*

This one may be OK. But no. It's too far gone. Ah! How about this one? No. It's too new.

MARGO: *(Pops her head out of the leaves in front of ON.)*

Hold it right there!

ON: Who are you?

MARGO: Who are you? more like! And what are you doing?

ON: I'm Oniscus, and I am searching for rotten leaves.

MARGO: Leaves, is it! Are you sure it's leaves you're after?

ON: Of course I'm sure. I am a woodlouse.

MARGO: I've heard about woodlice. Weird creatures that eat rotten leaves.

ON: That's what I said.

MARGO: Don't get clever with me. I'm just guarding my dead mouse.

ON: Whatever turns you on. *(Exits).*

MARGO: *(Vanishes back into the leaves)*

*[SOUND EFFECTS: Slurping, gobbling]*

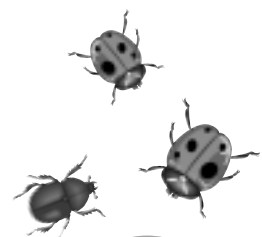



- NAR: Well, that's Margo the maggot for you. She's really tucking into her rotting mouse.
- ON: *(Re-enters)* Listen to that maggot. What a messy eater. And she'll be even worse when she grows into a fly.
- NAR: When maggots turn into flies they are sick all over their food before they eat it.
- SPECK: *(Flies in and flutters around above ON.)* Hi there, On! How are you today?
- ON: Oh hello, Speck. I'm fine. Just out looking for some nice, rotting leaves.
- SPECK: I don't know what you see in them. Give me some fresh nectar any day.
- ON: It's OK for you high fliers, sipping those exotic cocktails. But us workers have to keep our strength up, so it's good, old-fashioned plain food for me.
- SPECK: Oniscus, you need to get out more. Bye. *(Exits)*
- ON: *(Watches Speck fly off then bumps into the large BALL)*
- AR: My name's Armadelidium but most people call me Armie.
- ON: I'm Oniscus. On for short.
- AR: Hullo
- ON: How do you roll into a ball like that? None of my family can.
- AR: Really? Well, I guess we're different types you and me. All of my family can. It's a great trick. If anyone tries to eat you, just roll into a ball and you are safe as houses.
- ON: Impressive! What's all that noise.
- AR *(Enters, terrified)* A Dys! It's a Dys! A woodlouse spider. It will have us all for breakfast. Quick. Hide. I'm going to roll into a ball.
- (Exit left)*
- ON: Hide? Good plan! *(Dives under rock).*
- NAR: Just in time, Oniscus hides under a rock.
- DYS: *(Enters, crawling down side of screen. Exits left. Immediately re-enters pushing in BALL (AR) which it then attacks)*
- [SOUND EFFECTS: scraping noises].*
- NAR: The spider tries to bite the rolled-up woodlouse but its fangs just slide off the hard carapace ~ the woodlouse's hard, protective back.
- DYS: *(Enraged.)* Haaaaaah! Let me get at you! I'm hungry!
- NAR: Just then...
- ON: *(Peers out from under the rock).*
- NAR: ...the spider sees ON
- DYS: Ah! What's this? *(Moving towards ON)* A woodlouse that can't roll up!
- ON: *(Backs away up the rock, terrified).*

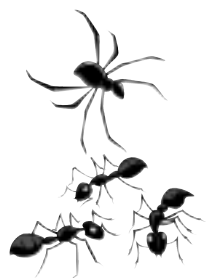



DYS: You look tasty! *(Jumps at ON)* Ha!

ON: Oooo er! (Turns around and runs up the side of the screen, along the top, and back down the other side)

DYS: *(Pursuing ON around the screen. Sweetly coaxing.)*  
Don't go, my friend. No need to be afraid.

NAR: Woodlice can't usually run very fast but, fortunately, to-day ...

*(ON scrambles over BALL and dives under rock.)*

...Oniscus escapes back to safety. Dysdera, the spider, is too big to follow him under the rock ...

*(DYS crashes into the rock and bounces back onto the ground.)*

*[SOUND EFFECTS: dull thud]*

DYS: Ouch!!

NAR: ... and crashes into the side of the rock, instead

DYS: *(Yells to ON)* Come out! *(Yells to BALL)* Unroll so that I can eat you!  
*(In disgust, kicks BALL offstage)* Idiot! At this rate, I'll starve *(Exits)*

ON: *(Pokes head out from under the rock)* Phew! *(Calls to AR)*  
Nice one, Armie! She's gone!

AR: *(Enters)* I hate that almost eaten feeling. I could feel her fangs scraping on my carapace.

ON: What was it?

AR: Dysdera are spiders whose favourite food is woodlice.

ON: Us!

AR: If you are not rolled up tight they can spear you right through the middle with those huge fangs.

ON: Gross! I'm out of here. I'll just ...*(Starts to dig in ground)*

*[SOUND EFFECTS: scuffling in leaves]*

take this *(Pulls LEAF up from below ground and, with an effort, starts to drag it up over the top of the rock)* Nice leaf. Thanks. 'Bye!. *(Exits)*



# Legless 1

Written by Peter Smithers & Jacolly Puppet Theatre



## CAST

### *Puppets/Puppeteers*

ONISCUS, a woodlouse  
GLOMERUS, a pill millipede  
ARMADELIDIUM, another kind of woodlouse  
INSECTA, an insect (maybe a butterfly, a ground beetle or a ladybird)

### *Voices*

ONISCUS, a woodlouse  
GLOMERUS, a pill millipede  
ARMADELIDIUM, another kind of woodlouse  
INSECTA, an insect (maybe a butterfly, a ground beetle or a ladybird)  
NARRATOR

### *Scenery*

(card/paper/coloured acetate with fabric leaves)

### *Sound effect producers*

There are leaves on the ground and a ball centre stage

NARRATOR: AR has taken ON to meet another minibeast who may be able to help ON find some good rotting leaves.

(Enter ON and AR who wander over to the ball and tap on it)

[SOUND EFFECTS: light tapping]

AR: Wake up Glom, you lazy thing. The day began hours ago.

GLO: (Muffled) Push off. Leave me alone.

AR: (Taps GLOM again)

[SOUND EFFECTS: LIGHT TAPPING]

Hey! We want your advice.

GLO: (Less muffled, as begins to unroll) Oh alright, alright. (Unrolls facing AR)

AR: Meet Oniscus.

GLO: On what?

ON: (Enters on top of rock) On - iscus.

GLO: (Turns around to face ON) What! You're just a woodlouse! Why should I want to meet a sad little woodlouse!

NAR: This gets On a little cross.

ON: So what's your problem then, mate. What makes you so different?

AR: (Exits, backwards)

(As they argue, GLOM marches around and ON shuffles up and down the rock)

GLO: (Outraged) What makes me different from you? How dare you! I'm not a woodlouse! I am a millipede. A pill millipede, if you must know. My family name is Glomerus and we millipedes are far more important than you common woodlice.

ON: So what's the big deal with being a millipede then, you great compost chomper!

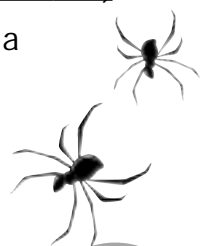

## Legless 2



NAR: Oh dear. On is getting really mad now.

GLO: We millipedes have two legs on each of our many segments, unlike you coarse crustacea. How many legs have you got?

ON: Fourteen

GLO: Only fourteen legs! And so few segments! Pathetic! Face it. I'm a superior life form!

ON: What! *(Shuffles to & fro making strange stuttering noises)*

NAR: This makes poor On so angry he doesn't know what to say. And Glom just looks smug...

GLO: Huh! *(Exits)*

NAR: ...and marches off into the wood.

ON: Well! How rude. There was really no need for any of that"

AR: *(Re-enters)* Sorry about that! Glomerus has been a bit strange about this leg thing lately. But he does know how to find the best leaves. There must be some specially tasty rotting leaves near here. Let's look.

INS: I can help you to find the food, I'm very good at finding food and I'm very important.

NAR: We know that there are many different kinds of minibeast and the number of legs that they have varies from 6 to over a hundred. Having more legs does not make them more important as they are all important. Without them the world would come to a halt.





# On the Ball 1

Written by Peter Smithers & Jacolly Puppet Theatre



## CAST

### *Puppets/Puppeteers*

ONISCUS, a woodlouse

BOMBUS, a bee

ARMADELIDIUM, another kind of woodlouse

### *Voices*

ONISCUS, a woodlouse

BOMBUS, a bee

ARMADELIDIUM, another kind of woodlouse

NARRATOR

### *Scenery*

(card/paper/coloured acetate with fabric leaves)

### *Sound effect producers*

There are leaves on the ground and a ball centre stage

NARRATOR: ON is out for a walk in the woods as part of his football training

ON: (Enter On who wanders along then bumps into the ball)

[SOUND EFFECTS: bump!]

ON: Ouch! What's this? Hey this could be good. I can get in some practice for the match on Saturday. (Rolls the ball around and then pretends he is playing football, butting the ball higher and higher into the air.)

[SOUND EFFECTS: the BALL always lands with a bump]

NAR: On the woodlouse has bumped into some kind of ball. Oh. Nice try, Oniscus!

BOM: (Off) Zzzzzz! Zzzzzzz!

NAR: Uh Oh! That sounds like Bombus the Bee. He's always fancied himself as a football commentator

BOM: (Flies in. Buzzes around screen, excited. Gets increasingly louder and faster) Zzzzzzzzz! ...And On takes the ball in a decisive tackle!

[SOUND EFFECTS: lots of cheering from the crowd]

He flies down the wing, weaving between defenders. What a performer. Look at this woodlouse go!

ON: (Heads BALL off screen).

BOM: He is past the backs and it's in the net.

[SOUND EFFECTS: crowd's final roar of approval]

What a goal! Zzzzzzzzz! (Exits)

ON: (Bows to imaginary audience) Thank you, fans.

AR: (Off) Oi! Leave it out mate.

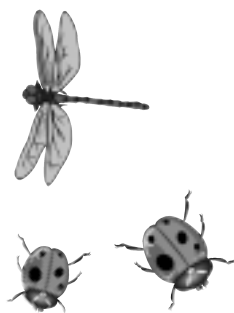

## On the Ball 2



ON: Who said that?

AR: *(Enters from side BALL had been kicked into)* Me, you dumb crustacean.

NAR: To On's surprise the ball has turned out to be another woodlouse.

AR: Will you stop kicking me around. It's not polite.

ON: Sorry mate. I didn't realise there was anyone in there. Who are you?

AR: My name's Armadelidium but most people call me Armie.

ON: I'm Oniscus. On for short.

AR: Hullo

ON: How do you roll into a ball like that? None of my family can.

AR: Really? Well. I guess we're different types you and me. All of my family can. It's a great trick. If anyone tries to eat you, just roll into a ball and you are safe as houses.

ON: Impressive!

AR: Do you play football for a team?

ON: Yes. I play for the Compost Kings. How about you?

AR: No. Not me. I always feel sorry for the ball.



# MINIBEAST WEB SITES

## Information for bug hunters on the internet.

You may like to find out more information about minibeasts using the internet. These sites have been recommended by the entomologists (insect specialists) at the University of Plymouth.

### FLORIDA BUG CLUB

An American web site for young bug hunters.  
<http://bugweb.entnem.ufl.edu/bugclub/>

### AES BUG CLUB

The site for British bug hunters. It contains information on British bugs and details of activities organised by the Bug Club.  
<http://www.exeter.ac.uk/bugclub/main.html>

**AES** (Amateur Entomological Society)  
<http://www.theaes.org/>

### GORDONS ENTOMOLOGICAL PAGE. THE WONDERFUL WORLD OF INSECTS

Lots of information on a wide range of minibeasts.  
<http://www.insect-world.com/six.html>

### BRITISH TARANTULA SOCIETY

How to keep Tarantulas and news of where to go and see them.  
<http://www.bts.ndirect.co.uk/>

### BRITISH DRAGONFLY SOCIETY

All about dragonflies in the UK.  
<http://www.dragonflysoc.org.uk/>

**ANT CAST** the web window on the life of ants.  
Live video footage from an ant colony.  
<http://www.nhm.ac.uk/museum/creepy/antcastintro.html>

**NAT HIST MUSEUM CREEPY CRAWLY EXHIBITION**  
A guide to the Bugs exhibit at the Natural History Museum London.  
<http://www.nhm.ac.uk/museum/creepy/index.html>

**MARK WATSONS STICK INSECT PAGE**  
All about Stick insects.  
<http://members.aol.com/fluffymark/home.htm>

**YOUNG ENTOMOLOGIST SOCIETY**  
<http://members.aol.com/YESbugs/bugclub.html>

**ORIGAMI: THE ARTHROPODA**  
This page contains origami bugs, spiders, and crustaceans.  
Jasper's Origami Menagerie (USA)  
<http://www.folds.net/menagerie/arthropoda.html>



# MINIBEAST BOOK LISTS

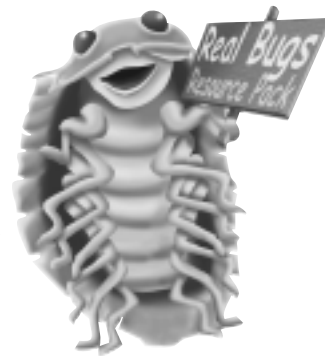

There are also some excellent books about insects. Libby Allman, a Children's Book Specialist at *In Other Words Bookshop Ltd*, has compiled a list of Fiction and Non-Fiction Books. You can contact the bookshop by writing to Libby Allman at *In Other Words Ltd*, 64 Mutley Plain, Plymouth, PL4 6LF, phoning **01752 663889** or emailing **books@inotherworlds.co.uk**.

## FICTION

	AUTHOR	PUBLISHER	ISBN
<b>PICTURE BOOKS</b>			
Very Hungry Caterpillar	Eric Carle	Puffin	0140500871
Bad Tempered Ladybird	Eric Carle	Puffin	0140503986
Beetle in the Bathroom	Brian Moses	Puffin	0140567046
Scratch Scratch	Miriam Moss	Orchard	1841211125
The Hoppameleon	Paul Geraghty	Red Fox	0099408538
Snail Trail	Ruth Brown	Anderson	0862649498
Ladybird Ladybird	Ruth Brown	Anderson	1842700405
Tiny	Paul Rogers	Bodley Head	0370326326
	[illustrated by Korcky Paul]		
<b>EARLY READERS</b>			
Little Bug series:	Damon Burnard	Hodder	
1. Cindy Centipede			0340787783
2. Wally Woodlouse			0340787791
3. Lilly and the Ladybirds			0340787805
4. Danny Longlegs			0340787813
Emily's Legs	Dick King- Smith	Hodder	0340854081
Spinderella	Julia Donaldson	Egmont	1405200723
Leon Loves Bugs	Dyan Sheldon	Walker	074457790X
Omnibombulator	Dick King-Smith	Transworld	0552527998
Little Stupendo	Jon Blake	Walker	074459023X
<b>LONGER READS</b>			
Harry the Poisonous Centipede	Lyn Reid Banks	Harper Collins	0006751970
Harry the Poisonous Centipede's Big Adventure	Lyn Reid Banks	Harper Collins	0006755356
Charlotte's Web	E.B.White	Puffin	0140364498
Invasion of the Vampire Spiders	Susan Gates	Puffin	014131074X
Spid	Ursula Moray Williams	Red Fox	0099408538
Bug Muldoon and the Garden of Fear	Paul Shipton	O.U.P.	019275274X
<b>POETRY</b>			
Minibeasts	chosen by Brian Moses	Mac	033037057X
Mini Beasties	chosen by Michael Rosen	Puffin	0140544909

# MINIBEAST BOOK LISTS

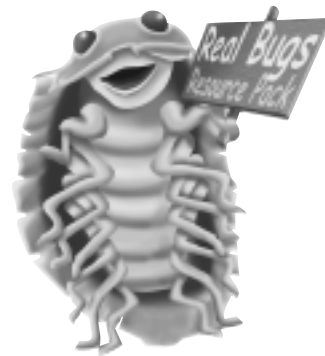

## INFORMATION BOOKS

Eyewitness Explorer :Insects	Dorling Kindersley	0751360953
Eyewitness Readers-Bugs, Bugs, Bugs	Dorling Kindersley	0751358576
Busy Buzzy Bee	Dorling Kindersley	0751362107
Spiders Secrets	Dorling Kindersley	0751345989
Usborne Beginners - Spiders		0746045425
Lift the Flap-Bugs and Slugs	Usborne	0746027737
Big Bug Search	Usborne	0746027036
Spotters Guides-Bugs and Insects	Usborne	0746040717
Fly Traps	Walker	0744562740
Caterpillar Caterpillar	Walker	0744536367
Oxford Reds- Spiders	O.U.P.	0199106894
Best Book of Creepy Crawlies	Kingfisher	0753403099
Question Time Creepy Crawlies	Kingfisher	0753406276
Are You a Ladybird?	Kingfisher	075340530X
Are You a Snail?	Kingfisher	0753406683
[Up the Garden Path Series]		
Awesome Facts about Bugs	Watts	0749639385
Awesome Facts about Spiders	Watts	0749639326
I wonder why Spiders Spin Webs	Kingfisher	0753407523
Looking at Minibeasts [series]		
Ladybirds and Beetles	Belitha	1841383902
What's Creepy and Crawly?	Frances Lincoln	0711218889
Usborne Discovery BUGS	Usborne	0746046944
Mega Bites Bugs	Dorling Kindersley	0751330817
Horrible Science: Ugly Bugs	Scholastic	0590558080
Horrible Science: Microscopic Monsters	Scholastic	0439995019

## USEFUL KEYS FOR MINIBEAST IDENTIFICATION.

The Woodland Name Trail. Ann & John Bebbington and Steve Tilling. Published by the Field Studies Council. A simple flow chart on a fold out card that identifies the main minibeast groups.

Minibeasts. An Identification Guide. Peter Smithers and John Walters. (available mid 2003). A more in depth flow chart that identifies all minibeast groups using easily observed features, with information about each of them.

A Key to the Terrestrial Invertebrates of the British Isles. Steve Tilling. Published by the Field Studies Council. An in depth scientific key for those who wish to take a scientific approach to minibeast identification. It contains information on the ecology of each group and references to other books that give more information about them.